

REVISIONS				
REV	DATE	DESCRIPTION	BY	CHK
A1	25APR2018	REVISED PER PCN E-18-005678	SM	CF
C	08JUN2020	REVISED PER PCN E-20-006323	VNB	GL
C1	30SEP2020	REVISED PER PCN E-20-014332	CK	GL
C2	02NOV2021	REVISED PER PCN-21-118664	DM	CRG

DELIVERY CONDITION AS SHOWN
Lieferzustand wie gezeigt

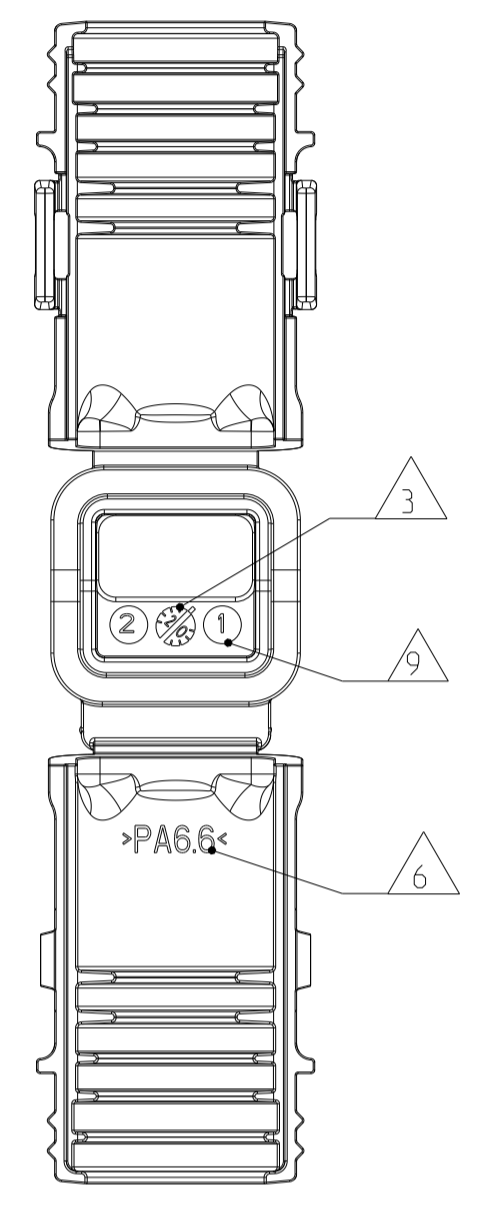
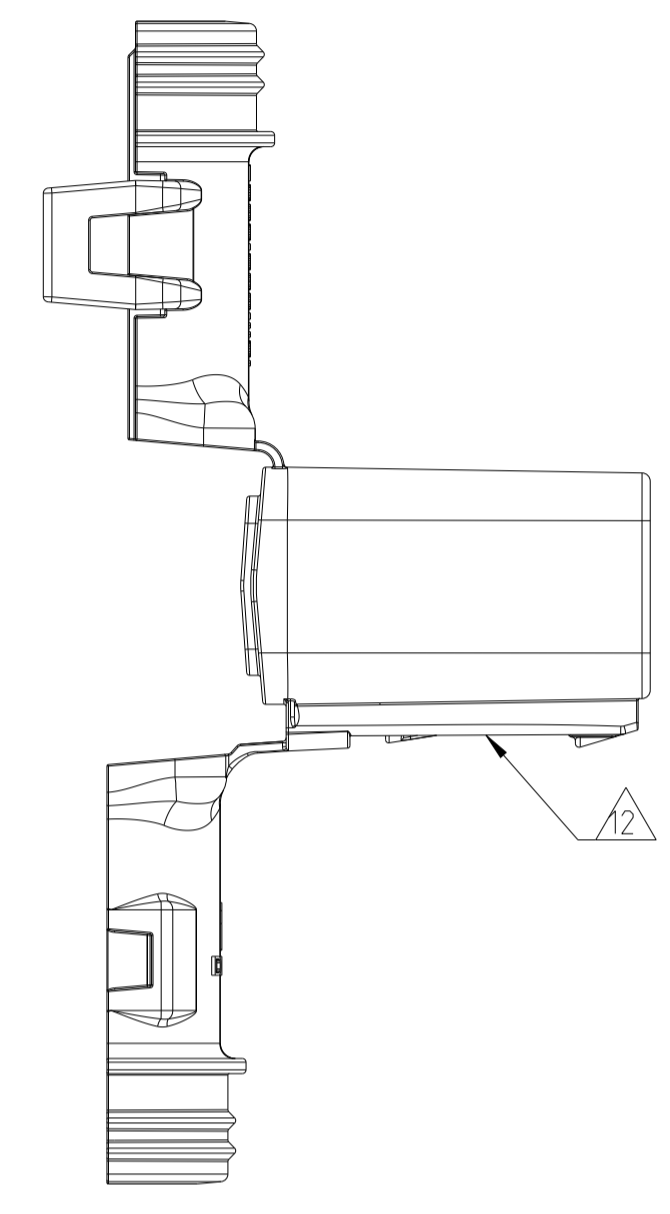
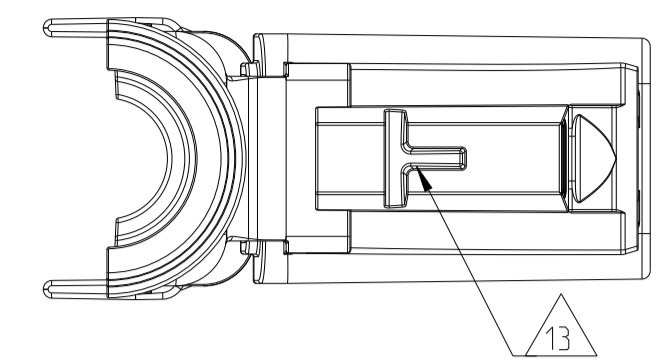
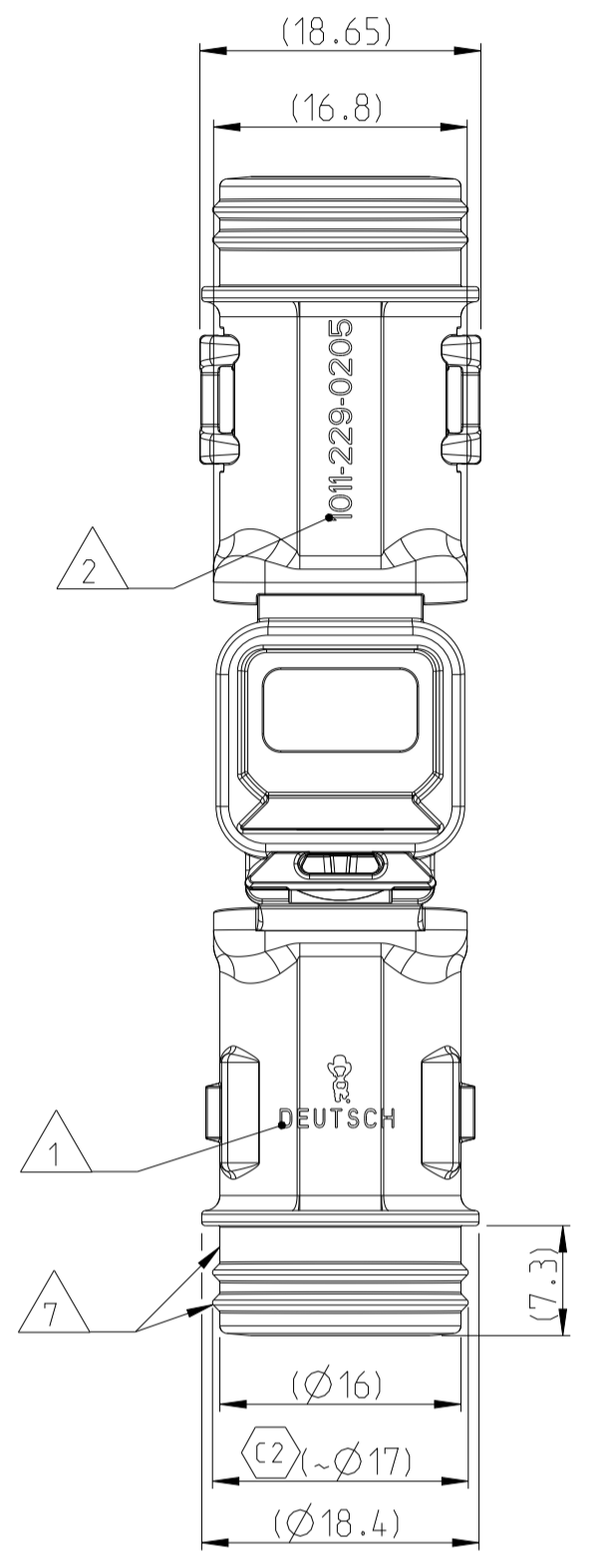

NOTES
Bemerkungen

- 1 DEUTSCH LOGO
DEUTSCH Logo
- 2 DEUTSCH PART-NO
DEUTSCH Teil-Nr.
- 3 PRODUCTION DATE
Produktionsdatum
- 4 BULK PACKAGING IN CORRUGATED BOX
Schuetztgut im Karton
- 5 MALFUNCTION CAUSED BY LAQUER IS NOT COVERED BY TE WARRANTY
Funktionsbeeinträchtigung durch Lackieren liegt nicht im Einfluss und Gewährleistungsumfang von TE
- 6 MATERIAL MARKING ACCORDING TO VDA 260
Werkstoffkennzeichnung nach VDA 260
- 7 FOR HEAT-SHRINK TUBING AND TUBE WITH TIE WRAP
Fuer Schrumpfschlauch und Schlauch mit Kabelschelle
- 8 FOR CORRUGATED TUBES: NW 6/7.5/8.5/10
Fuer Wellrohre: NW 6/7.5/8.5/10
- 9 CAVITY MARKING
Kammerbezeichnung
- 10 MATED WITH ALL MODIFICATION OF DT04-02P (WITHOUT ANY WELDED / MOUNTED PARTS)
Passend zu allen Varianten von DT04-02P (ohne verschweißte / montierte Teile)
- 11 BASED ON THE HINGE MECHANISM OF THE CAP, THE DELIVERY CONDITION CAN BE DIFFERENT TO THE SHOWN STATUS.
Basierend auf dem Klappmechanismus der Kappe, kann der Lieferzustand von der dargestellten Ansicht abweichen.
- 12 SWALLOW TAIL FOR DIVERSE BRACKETS AND ATTACHMENT CLIPS
Schwalbenschwanzführung für div. Befestigungsbügel und -clips
- 13 THE MISSING FEATURE READED
Die fehlende Funktion wurde gelesen

CLOSED (MOUNTED) CONDITION AS SHOWN
Geschlossener (montierter) Zustand wie gezeigt

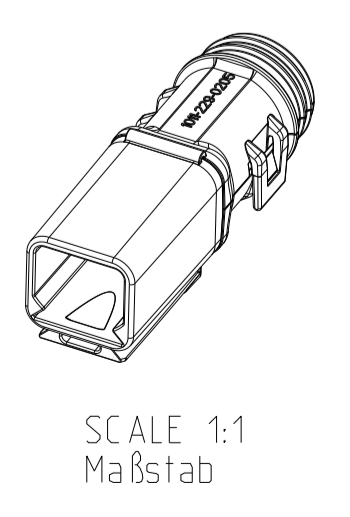
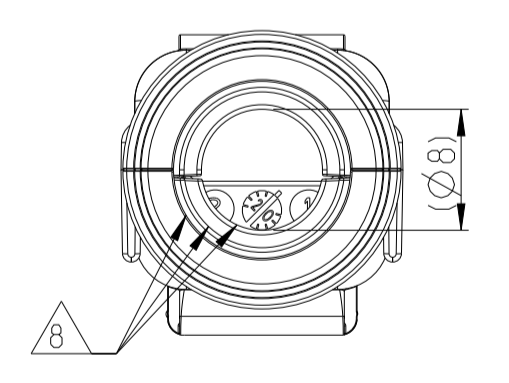
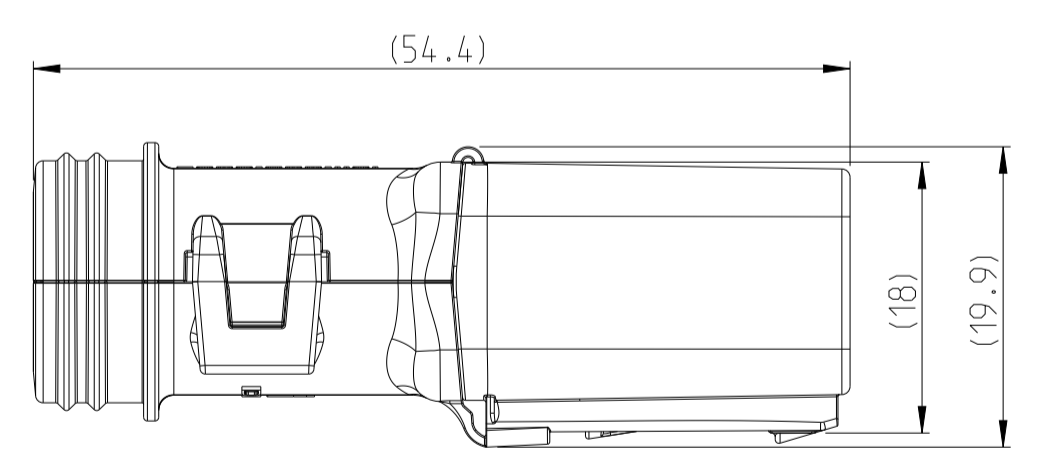

SECTION B-B
Schnitt
SCALE 5:1
Maßstab

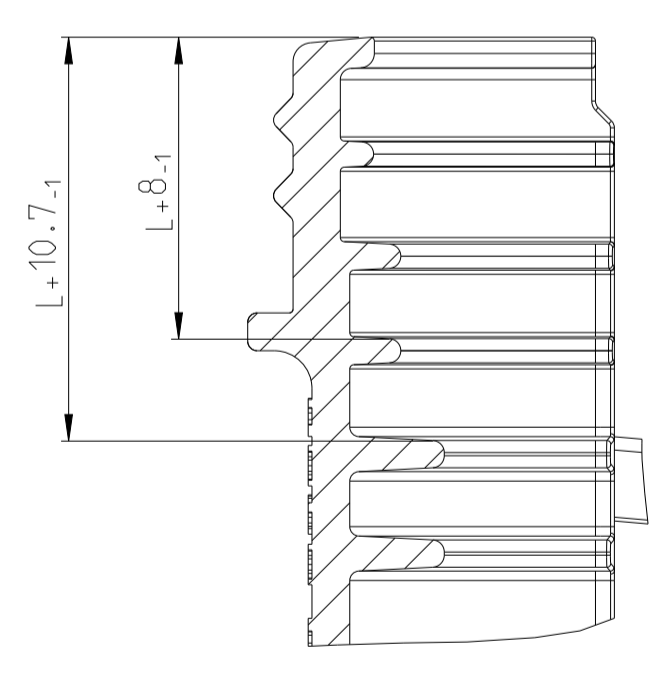

L+ = ADD LENGTH FOR CORRUGATED TUBE
zus. Länge des Wellrohres

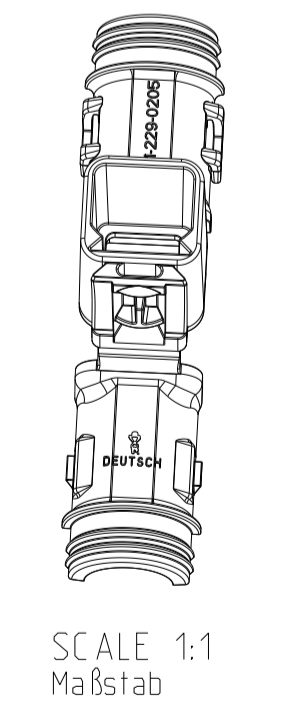

TOLERANCES UNLESS OTHERWISE SPECIFIED ACC. TO DIN 16901-140 CENTRIC TO NOMINAL DIMENSION, EDITION 1982-11 SHALL APPLY. Freimessstoleranzen nach DIN 16901-140. Es gilt die Ausgabe 1982-11.		DIESE ZEICHNUNG IST EIN KONTROLLIERTES DOKUMENT. BEMASSUNGEN UND TOLERANZEN GEMAESS GPS (ISO STANDARDS).	
THIS DRAWING IS A CONTROLLED DOCUMENT. DIMENSIONING AND TOLERANCING PER GPS (ISO STANDARDS).		DATE: 16JUL2013 DWG: KASHYAP CHK: C.F.INZNER	DATE: 16JUL2013 DWG: KASHYAP CHK: C.F.INZNER
DIMENSIONS: mm	TOLERANCES UNLESS OTHERWISE SPECIFIED: ACC. TO ISO 8013	APPROVED: C.F. BERWEIN PRODUCT SPEC	APPLICATION SPEC
FINISH: ANGLES: #1*		WEIGHT: SEE TABLE	CUSTOMER DRAWING

ORDER-NO. Bestell-Nr.	REV.	WEIGHT (g)	MATERIAL	COLOUR Farbe	DESCRIPTION Beschreibung	ITEM
1011-229-0205	C	6.3	NYLON 6/6	BLACK schwarz	COVER WITHOUT STRAIN RELIEF Kappe ohne Zugentlastung	1

TE TE Connectivity

NAME: COVER, DT04-02P-BS180
Kappe, DT04-02P-BS180
BACKSHELL STRAIGHT (180 DEGREE)

SIZE: 00779
SCALE: 2:1
SHEET: 1 OF 1
REV: 2