

Part number

CQF 07



female insert, CQ series, crimp connection, 7 poles + PE, 10 A 400 V 6 kV 3, size "21.21"

Product description		Material properties	
Product type	Insert	Main material	Polycarbonate (PC)
Series	CQ	Colour	RAL 7032 grey
Connection type	crimp connection		Compliant with exemption 6(c): copper alloy containing up to 4% lead by weight
Gender	female	RoHs conformity	
N. of poles	7 poles + 	China RoHs - EFUP	50
Size	size "21.21"	REACH SVHC substances	Yes Lead
Technical data		Approvals / Standards	
Current	10 A	Reference standard	EN 61984:2009-06
Voltage	400 V	Certifications	DNV-GL, BV, EAC
Rated impulse withstand voltage	6 kV	General ordering information	
Pollution degree	3	EAN13 code	8015747226776
Rated voltage according to UL/CSA	600 V	Packaging Information	
IP degree of protection	IP20 without enclosure, IP44/IP66/IP67/IP68/IP69 with enclosure	Packaging length	220,00 mm
Further technical details		Packaging height	130,00 mm
Characteristics according to EN 61984	10A 400V 6kV 3	Packaging width	240,00 mm
Mating cycles	≥ 500	Packaging weight	3,23 kg
Insulation resistance	≥ 10 GΩ	Packaging volume	6,86 dm ³
Contact resistance	≤ 3 mΩ	Packaging description	Carton box
Weight	14,00 g	Packaging quantity	200 Pcs
Operating temperature range (min, max)	-40 °C ... +125 °C	Packaging EAN code	8015747226806
UL 94 flammability rating	V-0	Sub-packaging length	197,00 mm
Tightening torque for PE connection	M3: 0,5 Nm; 4,4 lb.in (0,5 x 3 mm)	Sub-packaging height	35,00 mm
Tightening torque for fixing screws	M3: 0,5 Nm; 4,4 lb.in (Ph1 or 0,8 x 5,5 mm)	Sub-packaging width	113,00 mm
		Sub-packaging weight	0,65 kg
		Sub-packaging volume	0,78 dm ³
		Sub-packaging description	Carton tray
		Sub-packaging quantity	40 Pcs
		Sub-packaging EAN barcode	8015747226813

Part number
CQF 07



Catalogue drawings

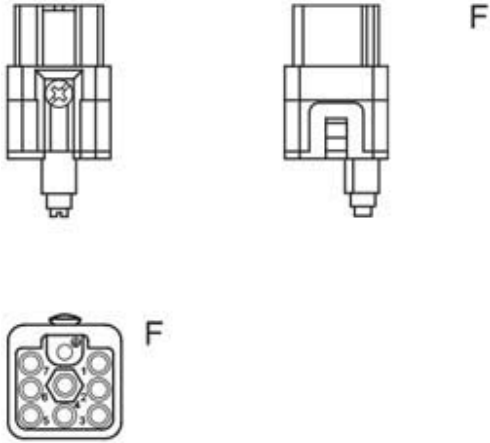

Derating curves

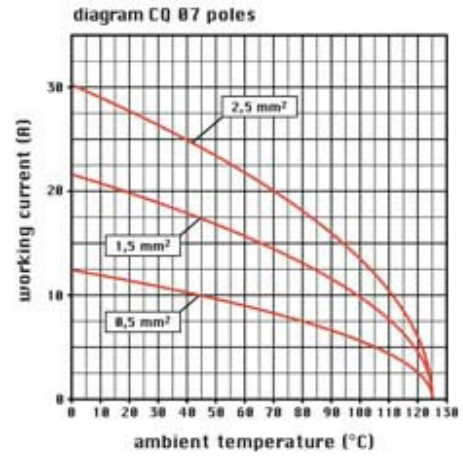

Notes

Dimensions shown in mm are not binding and may be changed without notice.