

Part number

# CSHF 16



female insert, CSH series, SQUICH® spring terminal connection without tools, 16 poles + PE, 16 A 500 V 6 kV 3, size "77.27"

## Product description

<b>Product type</b>	Insert
<b>Series</b>	CSH
<b>Connection type</b>	SQUICH® spring terminal connection without tools
<b>Gender</b>	female
<b>N. of poles</b>	16 poles +
<b>Size</b>	size "77.27"

## Technical data

<b>Current</b>	16 A
<b>Voltage</b>	500 V
<b>Rated impulse withstand voltage</b>	6 kV
<b>Pollution degree</b>	3
<b>Rated voltage according to UL/CSA</b>	600 V
<b>Wire cross-section</b>	0,14 mm <sup>2</sup> - 2,50 mm <sup>2</sup>
<b>AWG size</b>	26 - 14
<b>Contact type</b>	turned silver plated
<b>IP degree of protection</b>	IP20 without enclosure, IP65/IP66/IP68/IP69 with enclosure

## Further technical details

<b>Characteristics according to EN 61984</b>	16A 500V 6kV 3; 16A 400/690V 6kV 2
<b>Mating cycles</b>	≥ 500
<b>Insulation resistance</b>	≥ 10 GΩ
<b>Contact resistance</b>	≤ 3 mΩ
<b>Weight</b>	92,00 g
<b>Operating temperature range (min, max)</b>	-40 °C ... +125 °C
<b>Conductors stripping length</b>	9...11 mm
<b>UL 94 flammability rating</b>	V-0

## Material properties

<b>Main material</b>	Polycarbonate (PC)
<b>Other materials</b>	Contacts: copper alloy
<b>Colour</b>	RAL 7032 grey
<b>RoHs conformity</b>	Compliant with exemption 6(c): copper alloy containing up to 4% lead by weight
<b>China RoHs - EFUP</b>	50
<b>REACH SVHC substances</b>	Yes Lead

## Approvals / Standards

<b>Reference standard</b>	EN 61984:2009-06
<b>Certifications</b>	CSA, CQC, DNV-GL, BV, EAC
<b>UL</b>	PVVA2
<b>cUL</b>	PVVA8

## General ordering information

<b>EAN13 code</b>	8015747019255
<b>ETIM 7.0</b>	EC000438

## Packaging Information

<b>Packaging length</b>	245,00 mm
<b>Packaging height</b>	165,00 mm
<b>Packaging width</b>	215,00 mm
<b>Packaging weight</b>	3,26 kg
<b>Packaging volume</b>	8,69 dm <sup>3</sup>
<b>Packaging description</b>	Carton box
<b>Packaging quantity</b>	30 Pcs
<b>Packaging EAN code</b>	8015747170680
<b>Sub-packaging length</b>	197,00 mm
<b>Sub-packaging height</b>	44,00 mm
<b>Sub-packaging width</b>	113,00 mm
<b>Sub-packaging weight</b>	0,54 kg
<b>Sub-packaging volume</b>	0,98 dm <sup>3</sup>
<b>Sub-packaging description</b>	Carton tray
<b>Sub-packaging quantity</b>	5 Pcs
<b>Sub-packaging EAN barcode</b>	8015747170697

# Part number CSHF 16



Catalogue drawings

Catalogue drawings

dimensions in mm

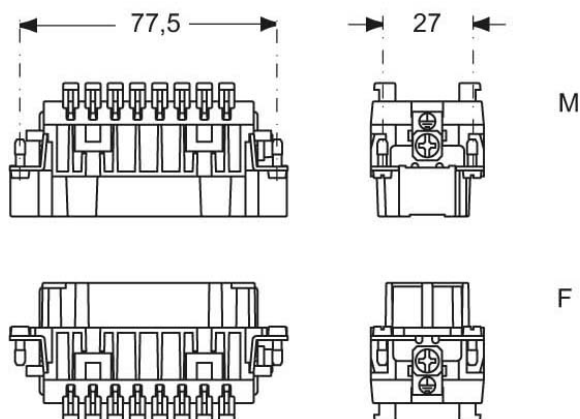

contacts side (front view)

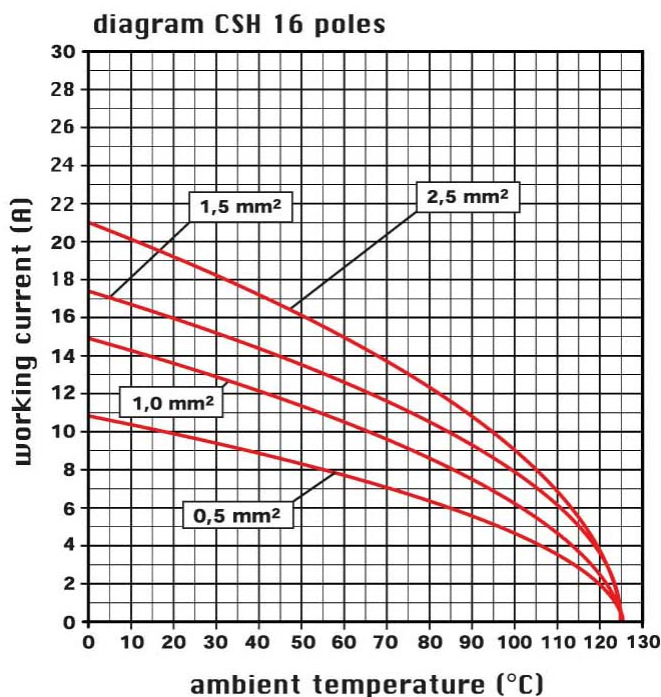
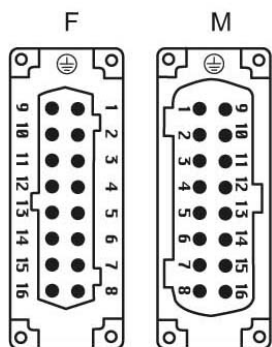

## Notes

CSHF/M 16

- characteristics according to EN 61984:

16A 500V 6kV 3

16A 400/690V 6kV 2

- rated voltage according to UL/CSA: 600V

- insulation resistance: > 10 GOhm

- ambient temperature limit: -40 °C ... +125 °C

- are made of self-extinguishing thermoplastic resin UL 94 V0

- mechanical life: > 500 cycles

- contact resistance: < 3 mOhm

- enclosures: size "77.27":

C-TYPE IP65/IP66

C7 IP67 stainless steel lever

V-TYPE IP65/IP66

stainless steel lever

T-TYPE IP65 insulating

JEI zinc-plated steel lever

BIG hoods

W-TYPE aggressive environments

EMC

central lever

IP68

- panel supports:

COB

Dimensions shown in mm are not binding and may be changed without notice.

SQUICH® connection with actuator button

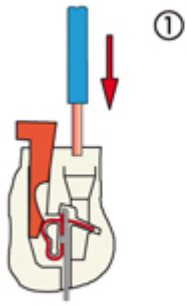

①

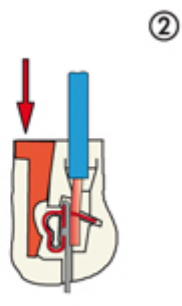

②

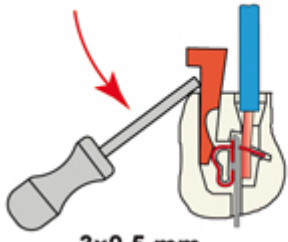

3x0,5 mm

Reopening

---