

Part number

CAV 24.29



Brief description:

hoods for two levers, size "104.27", top entry, Pg29, metal version, IP66

Product description

| | |
|---------------------|----------------------|
| Version | metal version |
| Series | hoods for two levers |
| Product type | with 4 pegs |
| Variant | top entry |
| Style | high construction |
| Family | CLASS enclosures |
| Size | size "104.27" |

Technical data

| | |
|--------------------------------|-------------------------------|
| Material | metal |
| IP degree of protection | IP66 (and IP69 DIN 40050 - 9) |
| Cable entry | Pg29 |

Further technical details

| | |
|---------------|----------|
| Weight | 214,00 g |
|---------------|----------|

Approvals / Standards

| | |
|---------------------|---|
| Quality mark |  (type:4/4X/12),  , EAC |
| Conformity | CQC, CE |

General ordering information

| | |
|----------------------|---------------|
| EAN13 code | 8015747010191 |
| Tariff number | 85369095 |

Packaging Information

| | |
|----------------------------------|----------------------|
| Packaging length | 245,00 mm |
| Packaging height | 165,00 mm |
| Packaging width | 215,00 mm |
| Packaging weight | 2,38 kg |
| Packaging volume | 8,69 dm ³ |
| Packaging description | Carton box |
| Packaging quantity | 10 Pcs |
| Packaging EAN code | 8015747010207 |
| Sub-packaging weight | 1,19 kg |
| Sub-packaging description | Carton box |
| Sub-packaging quantity | 5 Pcs |
| Sub-packaging EAN barcode | 8015747010214 |

Part number

CAV 24.29



Catalogue drawings

**CHO [CAO] CHV (CAV) - MHO [MAO]
MHV (MAV)**

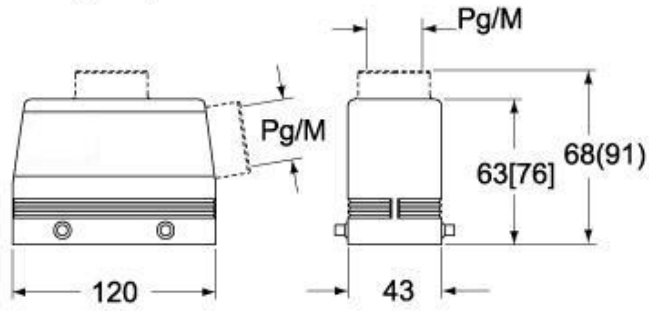

CHV G (CAV G) - MHV G (MAV G) - [MFV G]

