

Part number

CAV 10.21



Brief description:

hoods for two levers, size "57.27", top entry, Pg21, metal version, IP66

Product description	
Version	metal version
Series	hoods for two levers
Product type	with 4 pegs
Variant	top entry
Style	high construction
Family	CLASS enclosures
Size	size "57.27"
Technical data	
Material	metal
IP degree of protection	IP66 (and IP69K DIN 40050 - 9)
Cable entry	Pg21
Further technical details	
Weight	164,00 g

Approvals / Standards	
Quality mark	UL (type:4/4X/12), CE, EAC
Conformity	CQC, CE
General ordering information	
EAN13 code	8015747009386
Tariff number	85369095
Packaging Information	
Packaging length	180,00 mm
Packaging height	130,00 mm
Packaging width	270,00 mm
Packaging weight	1,64 kg
Packaging volume	6,32 dm ³
Packaging description	Carton box
Packaging quantity	10 Pcs
Packaging EAN code	8015747225922
Sub-packaging weight	0,82 kg
Sub-packaging description	Plastic pakaging
Sub-packaging quantity	5 Pcs
Sub-packaging EAN barcode	8015747009393

Part number

CAV 10.21



Catalogue drawings

**CHO [CAO] CHV (CAV) - MHO [MAO]
MHV (MAV)**

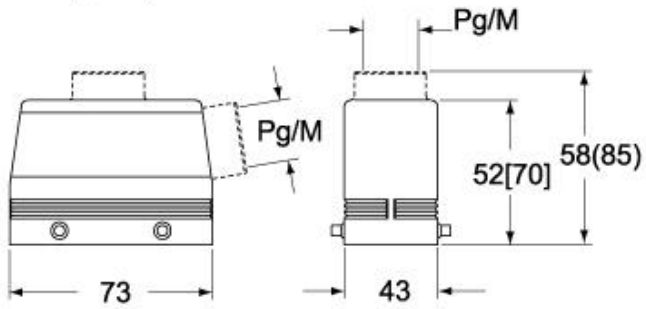

CAF - MAF/MFF

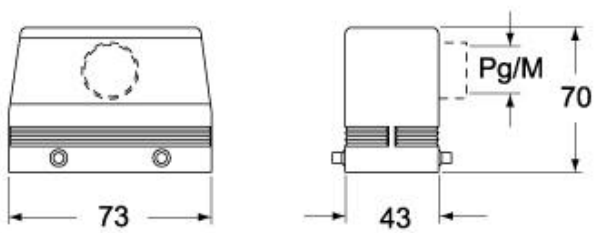

CHV G (CAV G) - MHV G (MAV G) - [MFV G]

